

DTS 3461C

TECHNICAL DATA SHEET

TECHNISCHES DATENBLATT / FICHA TÉCNICA / FICHE TECHNIQUE

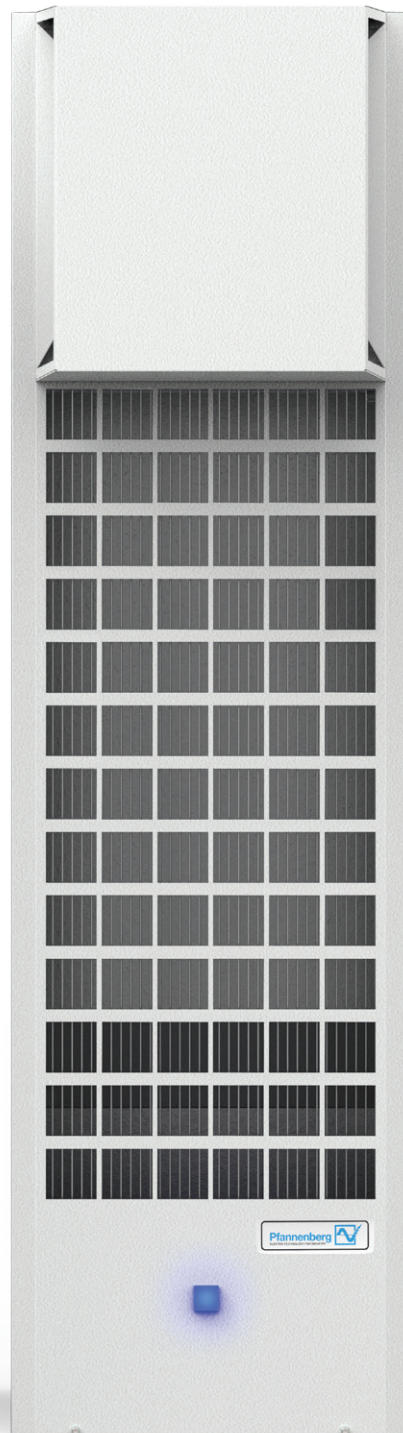

DTS 3461C

TECHNICAL DATA SHEET

TECHNISCHES DATENBLATT / FICHA TÉCNICA / FICHE TECHNIQUE



* All data based on 60Hz

COOLING DATA / KÄLTETEC HNISCHE DATEN / DATOS DE ENFRIAMIENTO / DONNÉES DE REFRROIDISSEMENT		230V		400V / 460V	
Cooling Capacity Kälteleistung / Capacidad de enfriamiento / Puissance de refroidissement	A95°F/95°F (A35°C/35°C)	20657 BTU/hr	6049 Watt	20901 BTU/hr	6120 Watt
	A122°F/95°F (A50°C/35°C)	11741 BTU/hr	3438 Watt	11636 BTU/hr	3407 Watt
Refrigerant Type & Amount Kältemittel-Typ & menge / Tipo & Cantidad de refrigerante / Type et quantité de réfrigérant		R-134a	650 grams	R-134a	650 grams
Adjustable Thermostat Setting 1TAS Thermostateinstellung (1TAS) / Ajuste de termostato / Réglage du thermostat	Factory Setting	95°F	35°C	95°F	35°C
Failure Indication: Enclosure Internal Temp. Störmeldung: Schaltschrank-Innentemp. / Señal de fallo: Temperatura interior del armario (ajuste de fábrica) / signal de défaut: Température intérieure de l'armoire (pré-réglage en usine)	Factory Setting	>122°F	>50°C	>122°F	>50°C
Ambient Air Temperature Umgebungslufttemperatur / Temperatura del aire ambiente / Température ambiante	Standard	25°F to 131°F	-4°C to 55°C	25°F to 131°F	-4°C to 55°C
	Optional - Low Ambient (LA)	-40°F to 131°F	-40°C to 55°C	-40°F to 131°F	-40°C to 55°C
	Optional -High Temp (HT)	N/A		N/A	
Air Volume, External Circulation Luftvolumenstrom, äußerer Kreislauf / Volumen de aire, circulación externa / Volume de l'air, circulation externe	A95°F/95°F (A35°C/35°C)	1234 CFM	2096 m³/h	1330 CFM	2259 m³/h
Air Volume, Internal Circulation Luftvolumenstrom, innerer Kreislauf / Volumen de aire, circulación interna / Volume de l'air, circulation interne	A95°F/95°F (A35°C/35°C)	558 CFM	948 m³/h	674 CFM	1145 m³/h
Condensation Discharge Kondensatabscheidung / Descarga de la condensación / Evacuation de condensation		Active evaporation tray; condensate overflow via hose		Active evaporation tray; condensate overflow via hose	
Optional Heating Data Heizungs kenndaten / Datos de calefacción / Données de chauffage	Thermostat Setting Termóstato	50°F	10°F	50°F	10°F
	Heating Capacity* Heizleistung / Capacidad de calefacción / Capacité de chauffage	3000 BTU/hr	900 Watt	3000 BTU/hr	900 Watt
*Heating element rating - actual capacity varies depending on airflow					

DTS 3461C

TECHNICAL DATA SHEET

TECHNISCHES DATENBLATT / FICHA TÉCNICA / FICHE TECHNIQUE



* All data based on 60Hz

ELECTRICAL DATA / ELEKTRISCHE KENNDATEN / DATOS ELÉCTRICOS / DONNÉES ÉLECTRIQUES		230 V		400V / 460V	
Operating range & phase (V, ~) unktionsbereich & phase / Rango de operación & fase / Plage de fonctionnement et phase	[V, Φ]	207V - 253V	1Φ	400V Setting: 380V - 420V 460V Setting: 414V - 506V	3Φ
Main Frequency Nennfrequenz / Fréquence nominale / Frecuencia nominal	Dual or Single Rating	60 hz		400V Setting: 60 Hz 460V Setting: 60 Hz	
Power Consumption Leistungsaufnahme / Consumo de energía / Consommation électrique	A95°F/95°F (A35°C/35°C)	2450 Watts		2431 Watts	
Nominal Running Current Nennlaufstrom / Corriente nominal de funcionamiento / Courant nominal de fonctionnement		11.82 A		4.06 A	
Minimum Circuit Ampacity (MCA) Minimale Stromkreisstärke / Máx. corriente admisible / Intensité minimale du circuit		14A		6A	
Maximum Over-Current Protection (MOP) Maximaler Überstromschutz / Protección contra sobretensión / Protection contre les surintensités maximale		23A		7A	
Recommended Maximum Fuse Size Empfohlene maximale sicherungsgröße / Tamaño máximo de fusible recomendado / Taille maximum recommandée de fusible		25A		10A	
Recommended Fuse Type Empfohlener Sicherungstyp / Tipo de fusible recomendado / Type de fusible recommandé		Class CC 600V Time Delay, Suitable for Transformer Inrush Protection Klasse CC 600V Zeitverzögerung, geeignet für Transformator-Einschaltstromschutz / Clase CC 600 V, con retardo, adecuado para protección en la entrada en transformadores / Classe CC 600 V avec délai, convient pour la protection d'entrée sur les transformateurs			
SCCR; kA		5kA		5kA	

ADDITIONAL INFO / ZUSÄTZLICHE INFO / INFORMACIÓN ADICIONAL / INFORMATIONS COMPLÉMENTAIRES	230 V		400V / 460V	
Dimensions (H x W x D) Abmessung (Höhe x Breite x Tiefe) / Dimensiones (Altura x Anchura x Profundidad) / Dimension (hauteur x largeur x profondeur)	57.2 x 15.8 x 19.7 in	1452 x 400 x 500 mm	57.2 x 15.8 x 19.7 in	1452 x 400 x 500 mm
Weight / Gewicht / Peso / Poids	210.1 lbs	95.3 kg	210.1 lbs	95.3 kg
Noise Level Lautstärke / nivel sonoro / niveau sonore	81 dB		81 dB	
Unit Construction Gerätekonstruktion / Construcción del dispositivo / Construction de l'appareil	Sheet Steel		Sheet Steel	
Corrosion Protection Korrosionsschutz / Protección anticorrosión / Protection anti-corrosion	G90 galvanized, electrostatically powder coated: RAL 7035 or ANSI61, Baked (200°C / 392°F)		G90 galvanized, electrostatically powder coated: RAL 7035 or ANSI61, Baked (200°C / 392°F)	
Protection Classification (against the enclosure) Schutzart (gegenüber dem Schaltschrank) / Clasificación de la protección (Para el gabinete) / Indice de protection (armoires électriques)	NEMA Type 3R/4 / IP 56 (EN 60529)		NEMA Type 3R/4 / IP 56 (EN 60529)	
Certifications Korrosionsschutz / Protección anticorrosión / Protection anti-corrosion	CE, cULus		CE, cULus	

DTS 3461C

TECHNICAL DATA SHEET

TECHNISCHES DATENBLATT / FICHA TÉCNICA / FICHE TECHNIQUE

COOLING CAPACITY CURVES

KÜHLEISTUNGSKURVEN / CURVAS DE CAPACIDAD DE ENFRIAMIENTO / COURBES DE CAPACITÉ DE REFROIDISSEMENT

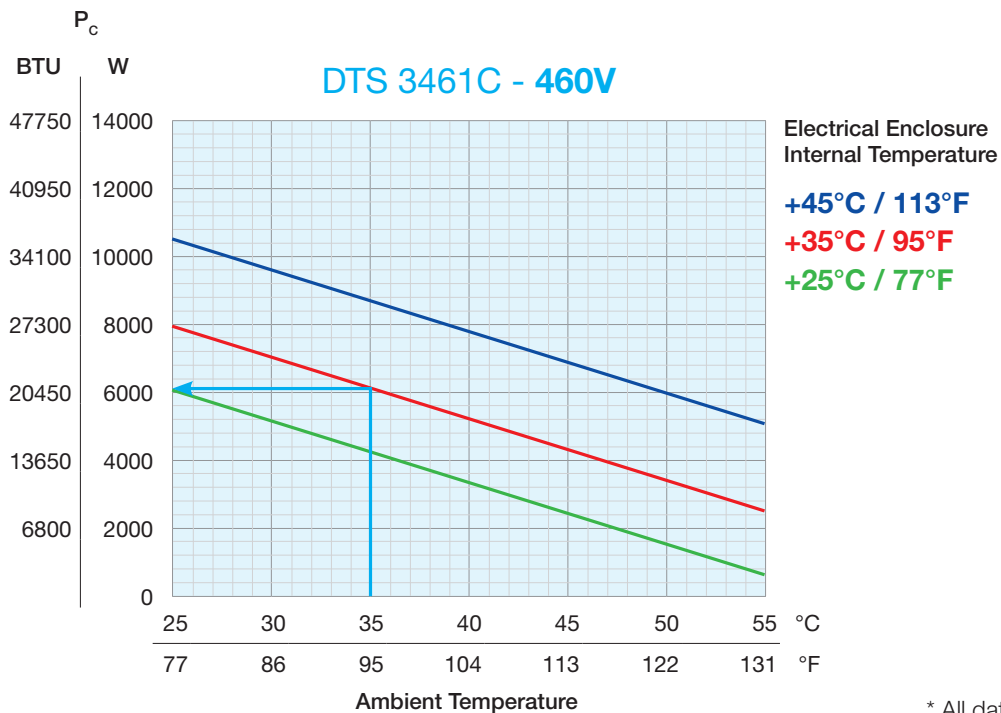
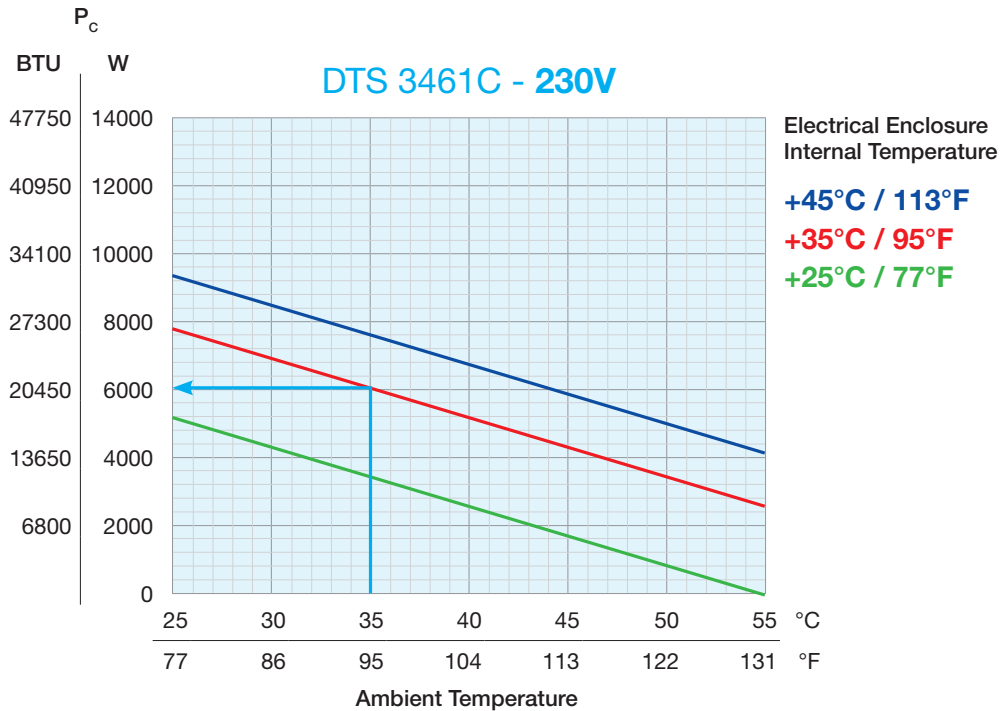

* All data based on 60Hz

DTS 3461C

TECHNICAL DATA SHEET

TECHNISCHES DATENBLATT / FICHA TÉCNICA / FICHE TECHNIQUE

Pfannenberg
ELECTRO-TECHNOLOGY FOR INDUSTRY



MOUNTING DETAILS

BEFESTIGUNGS DETAILS / DETALLES DE MONTAJE / DÉTAILS DE MONTAGE

Unit Dimensions / Air Flow / Sealing Gaskets

Geräteabmessungen / Luftstrom / Dichtungen
Dimensiones de la unidad / Flujo de aire / Junta de sellado
Dimensions de l'appareil / Débit d'air / Joint d'étanchéité

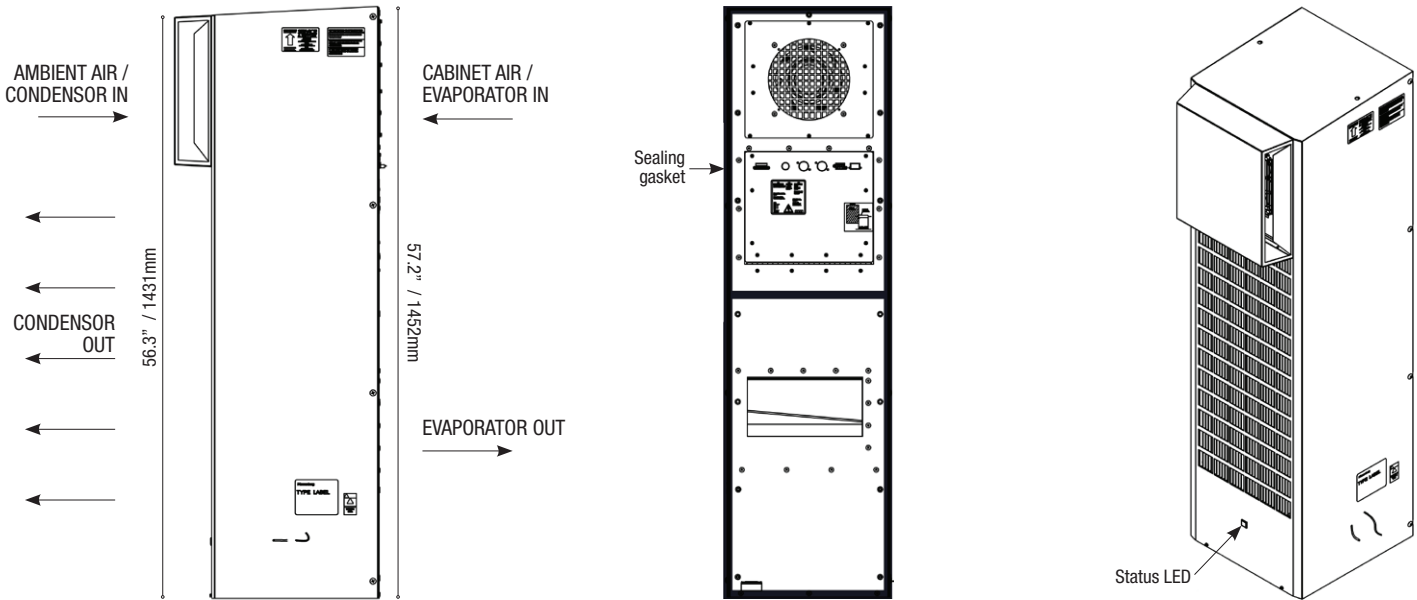
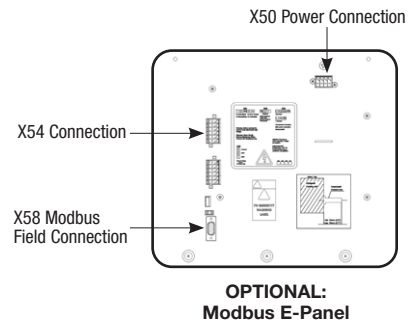
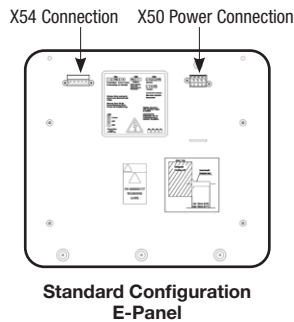
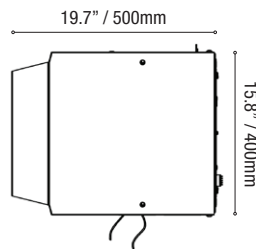

NOTICE:

- Prior to installation/operation of this unit, read installation /operation manual completely.
- Installation/operating should only be completed by properly trained personnel.
- Minimum distance to obstructions - 200mm (Exterior) - 100mm (Internal).
- DO NOT APPLY external voltage to door contact switch. Damage to unit my result.

ATENCIÓN:

- Antes de la instalación/puesta en marcha de esta unidad, leer atentamente el manual de instalación/operación.
- La instalación / puesta en marcha debe ser realizada únicamente por personal debidamente formado.
- Mínima distancia a obstáculos: - 200mm (Exterior) - 100mm (Interior).
- NO APLICAR tensión al contacto auxiliar de puerta. Se puede dañar la unidad.

ACHTUNG:

- Lesen Sie vor der Installation / dem Betrieb dieses Geräts die Installations- / Bedienungsanleitung vollständig durch.
- Installation / Betrieb sollte nur von entsprechend geschultem Personal durchgeführt werden
- Mindestabstand zu Hindernissen - 200 mm (Außen) - 100 mm (Innen)
- KEINE externe Spannung an den Türkontaktschalter anlegen. Schäden am Gerät können die Folge sein.

IMPORTANT:

- Avant d'installer ou d'utiliser cet appareil, veuillez lire entièrement le manuel d'installation et d'utilisation.
- L'installation/le fonctionnement ne doit être effectué que par un personnel dûment formé.
- Distance minimale aux obstacles - 200mm (extérieur) - 100mm (intérieur).
- NE PAS APPLIQUER de tension externe à l'interrupteur de contact de porte. Dommage à l'unité mon résultat.

DTS 3461C

TECHNICAL DATA SHEET

TECHNISCHES DATENBLATT / FICHA TÉCNICA / FICHE TECHNIQUE

Pfannenberg
ELECTRO-TECHNOLOGY FOR INDUSTRY



CUT-OUT

AUSSCHNITT /
PLANTILLA / DÉCOUPE

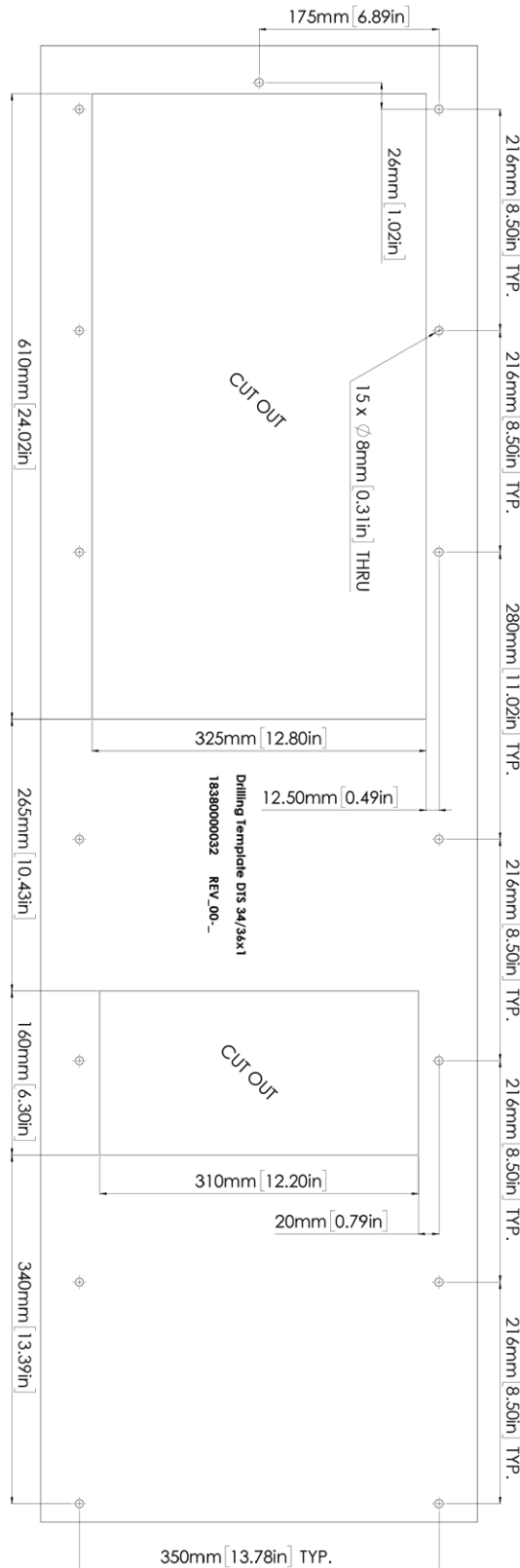

Installation & Wiring Instructions (Tech Manual)

Installations und Verdrahtungsanweisungen
(Technisches Handbuch) / Instrucciones de instalación y
cableado. (Manual Técnico) / Instructions d'installation et de
câblage (Manuel technique)



<https://indd.adobe.com/view/db28a6bf-9c39-4f9d-ae29-83bf0615432b>

CAD Files / CAD-Dateien / Ficheros CAD / Fichiers CAO



<https://www.pfannenbergsusa.com/product/thermal-management/cooling-units/dts-side-mount/dts-3461c/#toggle-id-3>

Spare Parts Diagram & Details

Ersatzteildiagramm und Details / Repuestos y detalles /
Diagrammes et Détails des pièces détachées



<https://www.pfannenbergsusa.com/spare-parts/>

CIRCUIT DIAGRAMS

SCHALTPLÄNE / DIAGRAMAS ELÉCTRICOS / SCHÉMAS ÉLECTRIQUES

230V Standard Configuration

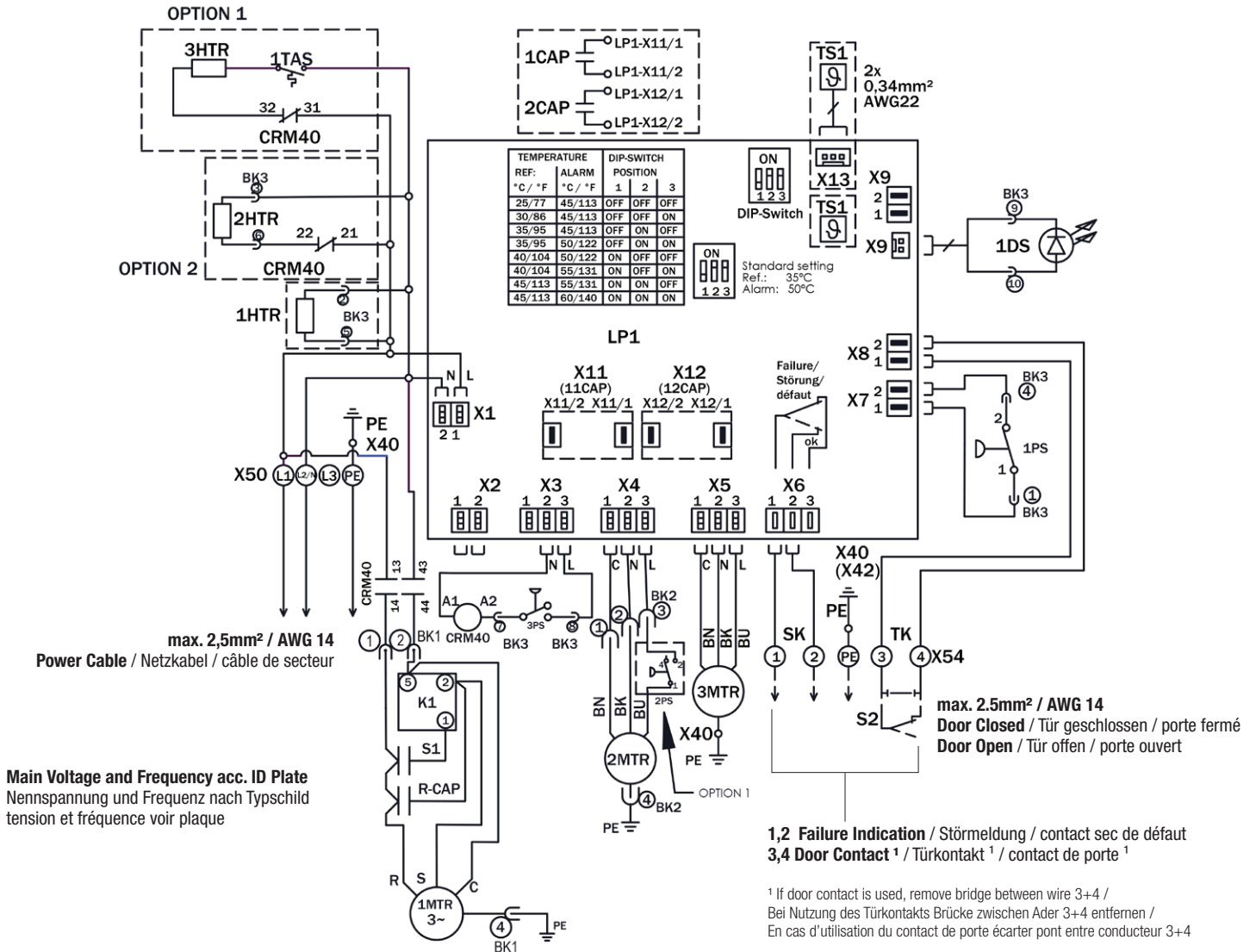

Main Voltage and Frequency acc. ID Plate
Nennspannung und Frequenz nach Typschild
tension et fréquence voir plaque

- | | |
|--|--|
| <p>1CAP / 11CAP Capacitors- condenser fan / Kondensator- Verflüssigerventilator/ condensateurs- ventilateur du condenseur</p> <p>2CAP / 12CAP Capacitors- evaporator fan / Kondensator- Verdampferventilator / condensateurs- ventilateur de l'évaporateur</p> <p>CRM20 CRM40 Relay: Compressor sump heater / Relais: Heizung Verdichter / relais: chauffage pour compresseur</p> <p>1PS High pressurestat / Hochdruckpressostat / pressostat haute pression</p> <p>2PS Fan cycle pressurestat / Pressostat / pressostat haute pression</p> <p>3PS Low Ref. Pressure / Niederdruckpressostat / pressostat basse pression</p> <p>1DS Operating indicator LED / Betriebsanzeige / Indicateur d'état opérationnel</p> <p>1HTR Heater-drip pan / Heizung-Kondensatwanne / chauffage-cuve de condensat</p> <p>2HTR Crankcase-heater / Kurbelgehäuse Heizung / carter de manivelle (chauffage)</p> <p>3HTR Heater / Heizung / chauffage</p> <p>LP1 PCB / Steuerplatine / platine</p> <p>1MTR Compressor / Verdichter / compresseur</p> | <p>2MTR Condenser fan / Verflüssiger- Ventilator / ventilateur du condenseur</p> <p>3MTR Evaporator fan / Verdampfer- Ventilator / ventilateur de l'évaporateur</p> <p>S2 Door contact / Türkontakt / contact de porte</p> <p>SK Failure indication / Störmeldekontakt Störmeldung / contact sec de défaut</p> <p>1TAS Thermostat / Thermostat / thermostat</p> <p>TK Door contact / Türkontakt / Contact de porte</p> <p>TS1 Temperature sensor internal / Temperatursensor intern / Capteur de température interne</p> <p>X40-42 Earthing connection / Klemmkontakt Masse / Contact de mise à terre</p> <p>X50 Connection mains / Klemmkontakt Netz / contact tension</p> <p>X54 Connection door contact + failure indication / Klemmkontakt Türkontakt + Störmeldung / contact contact de porte + sec de défaut</p> <p>S1 Start cap / Starten Cap / lancer cap</p> <p>K1 Potential relay / Potential Relais / Potentiel relais</p> <p>R-CAP Run cap / Führen Cap / exécutez Cap</p> <p>Option 1 Low ambient units / Niedrige Umgebungs Einheiten / Unités à basse température ambiante</p> <p>Option 2 Outdoor & wash-down units / Außeneinheiten / Unités extérieures</p> |
|--|--|

CIRCUIT DIAGRAMS

SCHALTPLÄNE / DIAGRAMAS ELÉCTRICOS / SCHÉMAS ÉLECTRIQUES

400V / 460V Standard Configuration

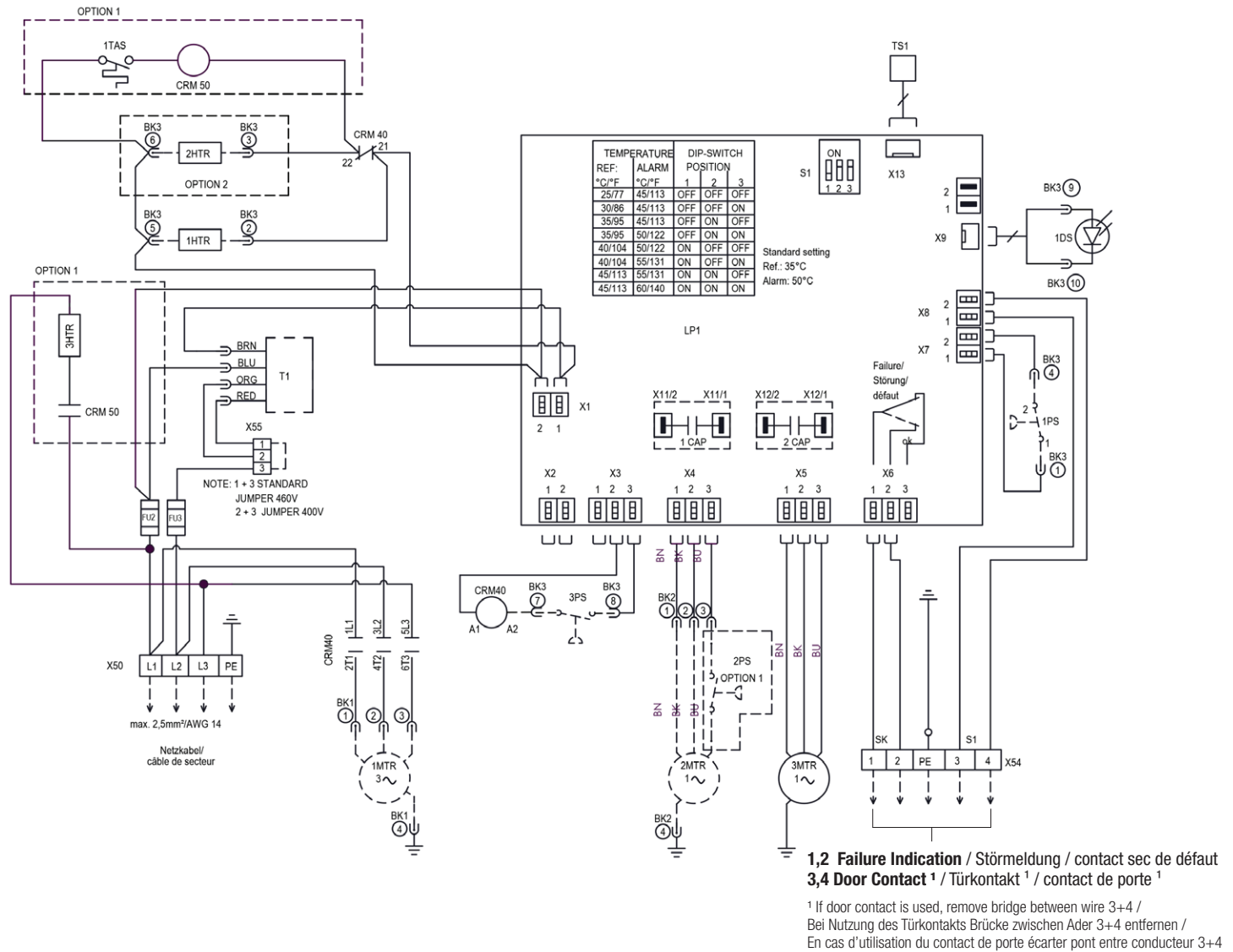

- 1 CAP** Capacitors- condenser fan / Kondensator- Verflüssigerventilator / condensateurs- ventilateur du condenseur
- 2CAP** Capacitors- evaporator fan / Kondensator- Verdampferventilator / condensateurs- ventilateur de l'évaporateur
- CRM40** Main-relay / Hauptrelais / relais principal
- FU2** Fuse / Sicherung / Fusible
- FU3** Fuse / Sicherung / Fusible
- 1PS** High pressurestat / Hochdruckpressostat / pressostat haute pression
- 2PS** Fan cycle pressurestat / Pressostat / pressostat haute pression
- 3PS** Low Ref. Pressure / Niederdruckpressostat / pressostat basse pression
- 1DS** Operating indicator LED / Betriebsanzeige / Indicateur d'état opérationnel
- 1HTR** Heater-drip pan / Heizung-Kondensatwanne / chauffage-cuve de condensat
- 2HTR** Crankcase-heater / Kurbelgehäuse Heizung / carter de manivelle (chauffage)
- 3HTR** Heater / Heizung / chauffage
- LP1** PCB / Steuerplatine / platine
- OLR** Overload Relay / Überlastrelais / relais de surcharge

- 1MTR** Compressor / Verdichter / compresseur
- 2MTR** Condenser fan / Verflüssiger- Ventilator / ventilateur du condenseur
- 3MTR** Evaporator fan / Verdampfer- Ventilator / ventilateur de l'évaporateur
- S1** Door contact / Türkontakt/ contact de porte
- SK** Failure indication / Störmeldekontakt Störmeldung / contact sec de défaut
- T1** Transformer / Transformator / Transformateur
- TS1** Temperatur sensor internal / Temperatursensor intern / Capteur de température interne
- X50** Connection mains / Klemmkontakt Netz / contact tension
- X54** Connection door contact + failure indication / Klemmkontakt Türkontakt + Störmeldung / contact contact de porte + sec de défaut
- X55** Transformer Switch / Transformator-Schalter / Transformateur Commutateur
(3+1=460V; 3+2=400V)
- X56** Thermostat connection / Thermostat Masse / Raccordement de thermostat
- CRM 50** Heater relay
- 1TAS** Heater Thermostat
- Option 1** Low Ambient Units / Niedrige Umgebungs Einheiten / Unités à basse température ambiante
- Option 2** Outdoor & Wash-down Units / Außenheiten / Unités extérieures

CIRCUIT DIAGRAMS

SCHALTPLÄNE / DIAGRAMAS ELÉCTRICOS / SCHÉMAS ÉLECTRIQUES

OPTIONAL 230V Modbus Configuration

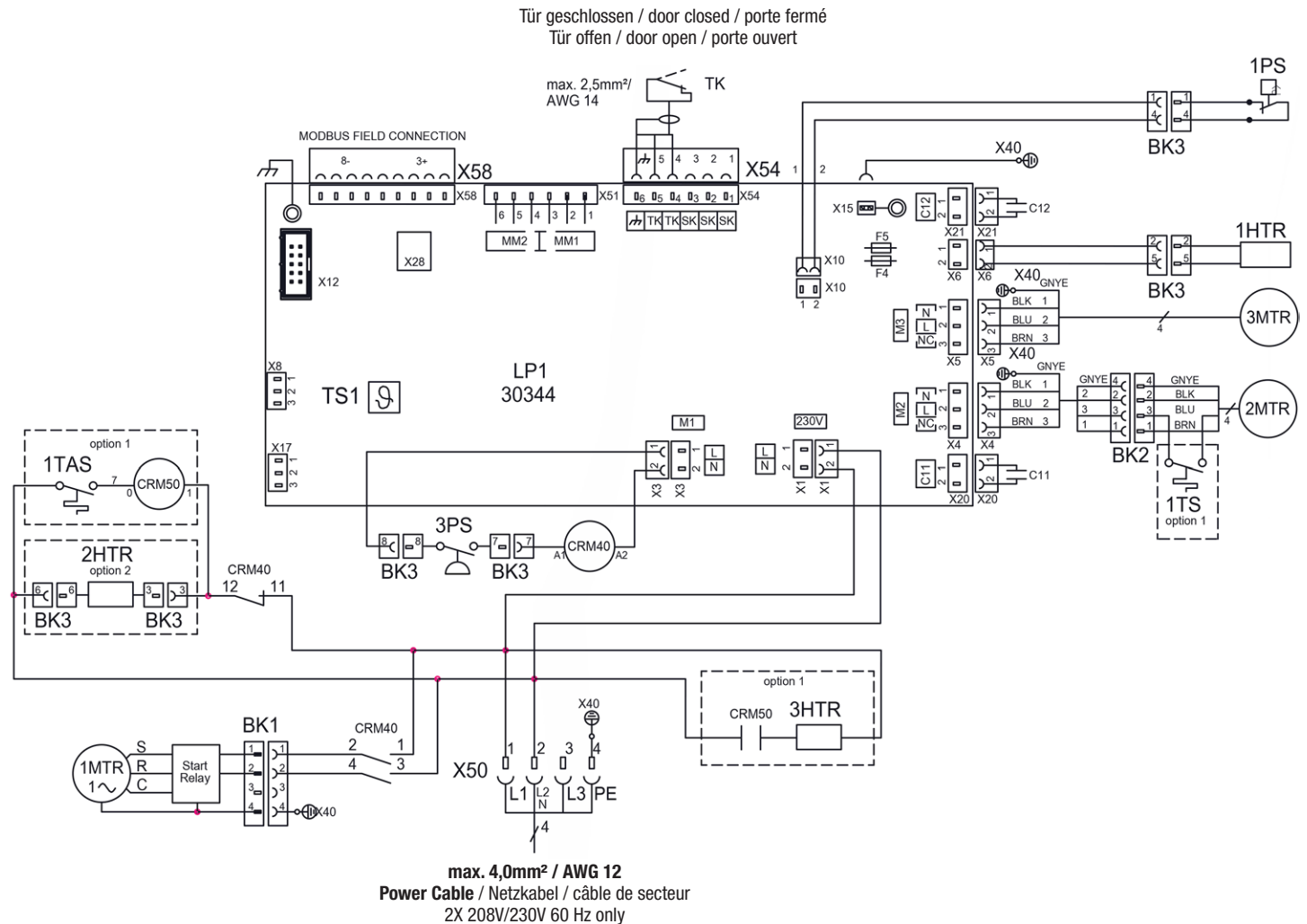

C11	Capacitors - condenser fan / Kondensator- Verflüssigerventilator / condensateurs- ventilateur du condenseur
C12	Capacitors- evaporator fan / Kondensator- Verdampferventilator / condensateurs- ventilateur de l'évaporateur
1PS	High pressurestat / Hochdruckpressostat / pressostat haute pression
3PS	Low ref. pressure / Niederdruckpressostat / pressostat basse pression
F4-F5	Sicherung / fuse / fusible
1HTR	Heater-drip pan / Heizung-Kondensatwanne / chauffage-cuve de condensat
2HTR	Crankcase-heater / Kurbelgehäuse Heizung / carter de manivelle (chauffage)
3HTR	Heater / Heizung / chauffage
CRM40	Contacteur compresseur / Schütz Verdichter / contacteur du compresseur
LP1	PCB / Steuerplatine / platine
1MTR	Compressor / Verdichter / compresseur

2MTR	Condenser fan / Verflüssiger- Ventilator / ventilateur du condenseur
3MTR	Evaporator fan / Verdampfer- Ventilator / ventilateur de l'évaporateur
TK	Door contact / Türkontakt / Contact de porte
TS1	Temperature sensor internal / Temperatursensor intern / Capteur de température interne
X40	Earthing connection / Klemmkontakt Masse / Contact de mise à terre
X50	Connection mains / Klemmkontakt Netz / contact tension
X54	Connection door contact + failure indication / Klemmkontakt Türkontakt + Störmeldung / contact contact de porte + sec de défaut
X58	Fieldbus RS485
1TAS	Heater Thermostat
1TS	Fan Cycle Temp Switch
Option 1	Low Ambient Units / Niedrige Umgebungs Einheiten / Unités à basse température ambiante
Option 2	Outdoor & Wash-down Units / Außenheiten / Unités extérieures

CIRCUIT DIAGRAMS

SCHALTPLÄNE / DIAGRAMAS ELÉCTRICOS / SCHÉMAS ÉLECTRIQUES

OPTIONAL

400V / 460V Modbus Configuration

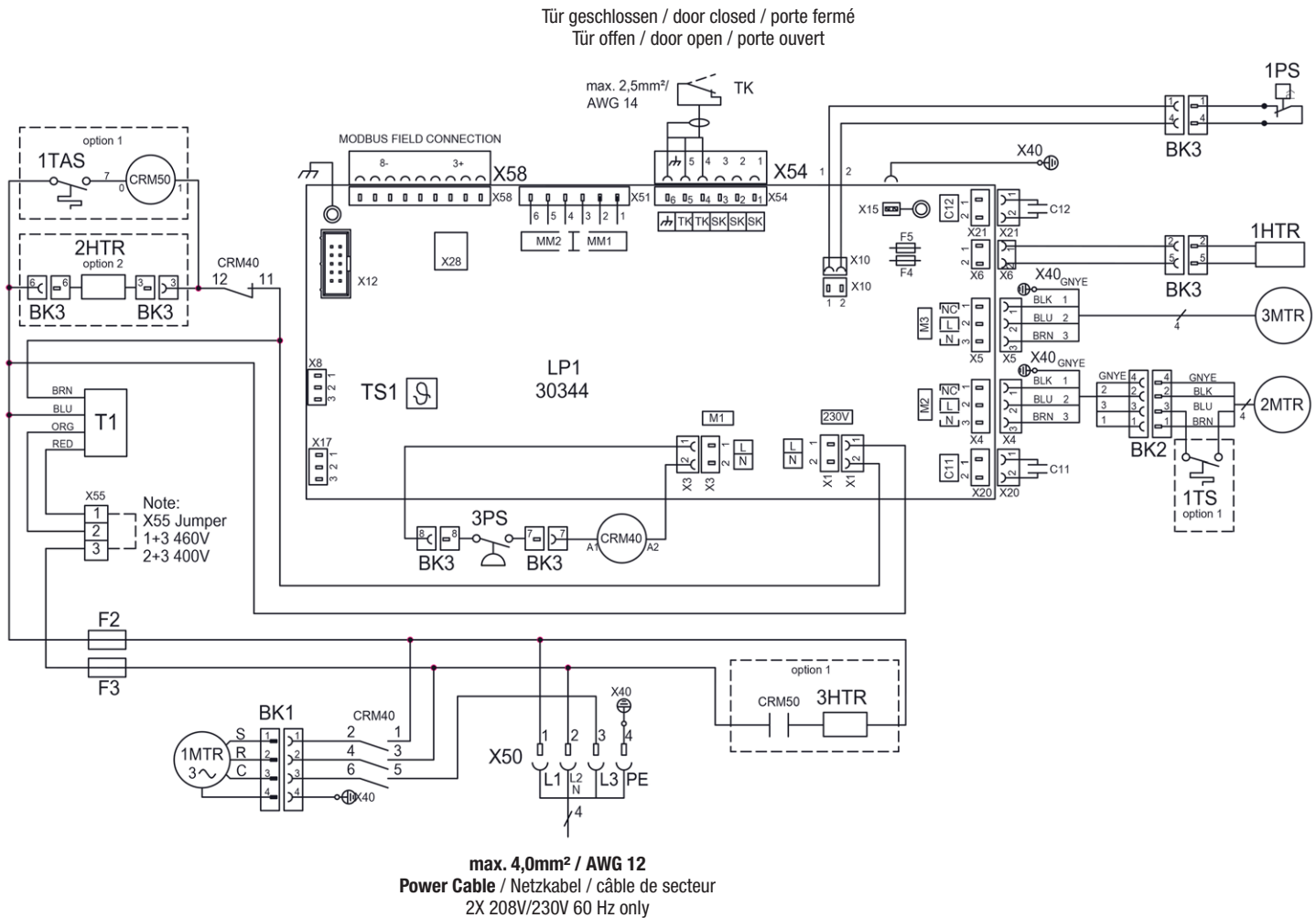

- | | |
|--|--|
| <p>C11 Capacitors- condenser fan / kondensator- verflüssigerventilator / condensateurs- ventilateur du condenseur</p> <p>C12 Capacitors- evaporator fan / Kondensator- Verdampferventilator / condensateurs- ventilateur de l'évaporateur</p> <p>1PS High pressurestat / Hochdruckpressostat / pressostat haute pression</p> <p>1TS Fan cycle Temp Switch / Pressostat / resostat haute pression</p> <p>3PS Low Ref. Pressure / Nierdruckpressostat / pressostat basse pression</p> <p>F2-F5 Fuse / Sicherung / fusible</p> <p>1HTR Heater condensate / Heizung Kondensat / chauffage pour le condensat</p> <p>CRM40 Contactor compressor / schütz Verdichter / contacteur du compresseur</p> <p>LP1 PCB / steuerplatine / platine</p> <p>1MTR Compressor / verdichter / compresseur</p> <p>2MTR Condenser fan / verflüssiger- ventilator / ventilateur du condenseur</p> <p>3MTR Evaporator fan / verdampfer- ventilator / ventilateur de l'évaporateur</p> | <p>2HTR Crankcase-heater / kurbelgehäuse Heizung / carter de manivelle (chauffage)</p> <p>3HTR Heater / Heizung / chauffage</p> <p>T1 Control transformer / Steuertransformator / transformateur de contrôle</p> <p>TK Door contact / Türkontakt / Contact de porte</p> <p>TS1 Temperature sensor internal / Temperatursensor intern / Capteur de température interne</p> <p>X40 Earthing connection / Klemmkontakt Masse / Contact de mise à terre</p> <p>X50 Connection mains / Klemmkontakt Netz / contact tension</p> <p>X54 Connection door contact + failure indication / Klemmkontakt Türkontakt + Störmeldung / contact contact de porte + sec de défaut</p> <p>X58 Fieldbus RS485</p> <p>1TAS Heater Thermostat</p> <p>Option 1 Low Ambient Units / Niedrige Umgebungs Einheiten / Unités à basse température ambiante</p> <p>Option 2 Outdoor & Wash-down Units / Außenheiten / Unités extérieures</p> |
|--|--|